

KIT TELESCOPICO DUE ANTE TWO-LEAVES TELESCOPIC KIT

Kit accessori in acciaio zincato e fune trascinamento con anima in propilene per la realizzazione di cancelli telescopici a due ante
Galvanized accessories kit with propylene cable for the construction of two leaves telescopic gates.

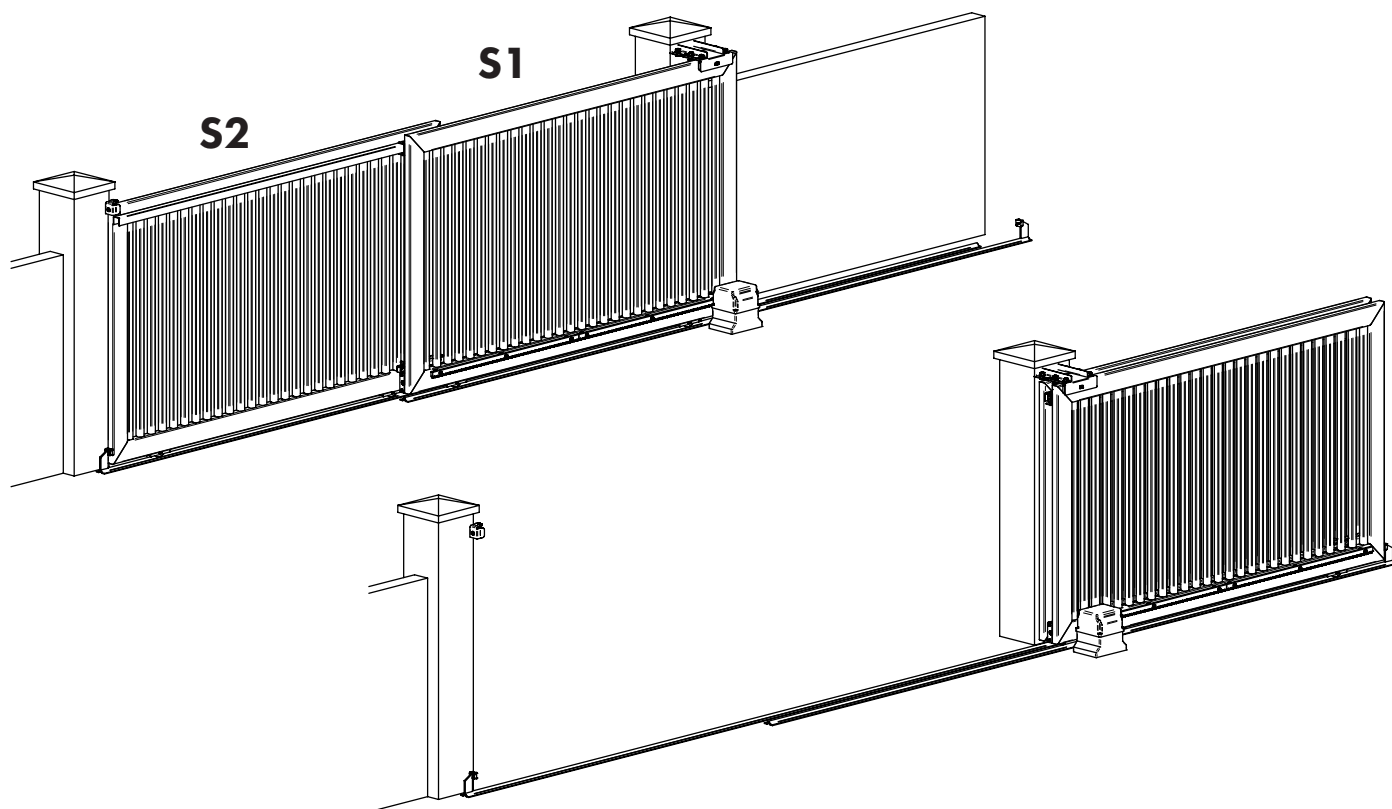

APERTURA FINO A 4m - OPENING UP TO 4m

KA5100.104	Con ruota D.90 gola V / D.90 V groove wheels	M
KA5100.404	Con ruota D.90 gola tonda 20mm / D.90 half-round groove wheels 20mm	M

APERTURA FINO A 8m - OPENING UP TO 8m

KA5100.108	Con ruota D.90 gola V / D.90 V groove wheels	M
KA5100.408	Con ruota D.90 gola tonda 20mm / D.90 half-round groove wheels 20mm	M

APERTURA FINO A 11m - OPENING UP TO 11m









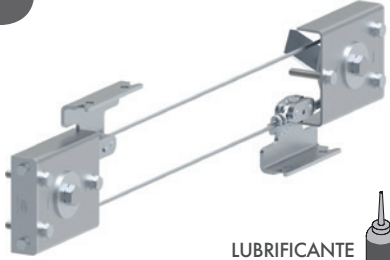

KA5100.111	Con ruota D.100 gola V / D.100 V groove wheels	M
KA5100.411	Con ruota D.100 gola tonda 20mm / D.100 half-round groove wheels 20mm	M

APERTURA FINO A 15m - OPENING UP TO 15m

KA5100.115	Con ruota D.100 gola V / D.100 V groove wheels	M
KA5100.415	Con ruota D.100 gola tonda 20mm / D.100 half-round groove wheels 20mm	M





COMPONENTI
COMPONENTS

<p>x1</p> 	<table border="1"> <tr> <td>A max</td> <td>4m</td> <td>8m</td> <td>11m</td> <td>15m</td> </tr> <tr> <td>n° pz</td> <td>1</td> <td>1</td> <td>2</td> <td>2</td> </tr> </table> 	A max	4m	8m	11m	15m	n° pz	1	1	2	2	<p>x1</p>  <p>LUBRIFICANTE INCLUSO OIL INCLUDED</p> 
A max	4m	8m	11m	15m								
n° pz	1	1	2	2								
<p>VA3501</p>	<p>VA3502</p>	<p>VA5101</p>										
<p>x1</p> 	<table border="1"> <tr> <td>A max</td> <td>4m</td> <td>8m</td> <td>11m</td> <td>15m</td> </tr> <tr> <td>n° pz</td> <td>2</td> <td>4</td> <td>6</td> <td>8</td> </tr> </table> 	A max	4m	8m	11m	15m	n° pz	2	4	6	8	<p>x3</p> 
A max	4m	8m	11m	15m								
n° pz	2	4	6	8								
<p>VA5201</p>	<p>VA5301</p>	<p>VA4101</p>										
<p>x4</p>  	<table border="1"> <tr> <td>A max</td> <td>4m</td> <td>8m</td> <td>11m</td> <td>15m</td> </tr> <tr> <td>n° pz</td> <td>6</td> <td>10</td> <td>13</td> <td>17</td> </tr> </table> 	A max	4m	8m	11m	15m	n° pz	6	10	13	17	
A max	4m	8m	11m	15m								
n° pz	6	10	13	17								
<p>VA1104</p>	<p>VA5411</p>											

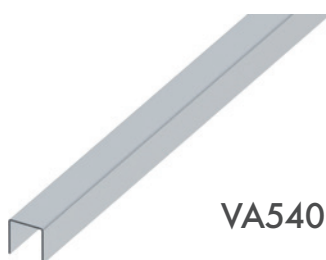

ARTICOLI CORRELATI
RELATED ARTICLES

 <p>VA5401</p>	 <p>VA2102 VA2402</p>	 <p>VA4203</p>
---	--	---



TABELLA DIMENSIONI
SIZE CHART

CODE	GOLA GROOVE	A max (m)	C (m)	D min (mm)	S2 max (kg)
KA5100.104	V	4	0,3	50	300
KA5100.404	U				
KA5100.108	V	8	0,3	50	300
KA5100.408	U				
KA5100.111	V	11	0,6	70	400
KA5100.411	U				
KA5100.115	V	15	0,6	70	400
KA5100.415	U				

ESEMPIO MISURE FUORI TABELLA
EXAMPLE OF OUT-OF-TABLE MEASUREMENTS

A = 3,5 m
 B = 0,06 m (scelta dall'installatore / selected by the customer)
 C = 0,3 m (da tabella sopra / as per above table)
 L = [(A+B)/2] + C
 L = [(3,5+0,06)/2] + 0,3
 L = [(3,56)/2] + 0,3
 L = 1,78 + 0,3
 L = 2,08

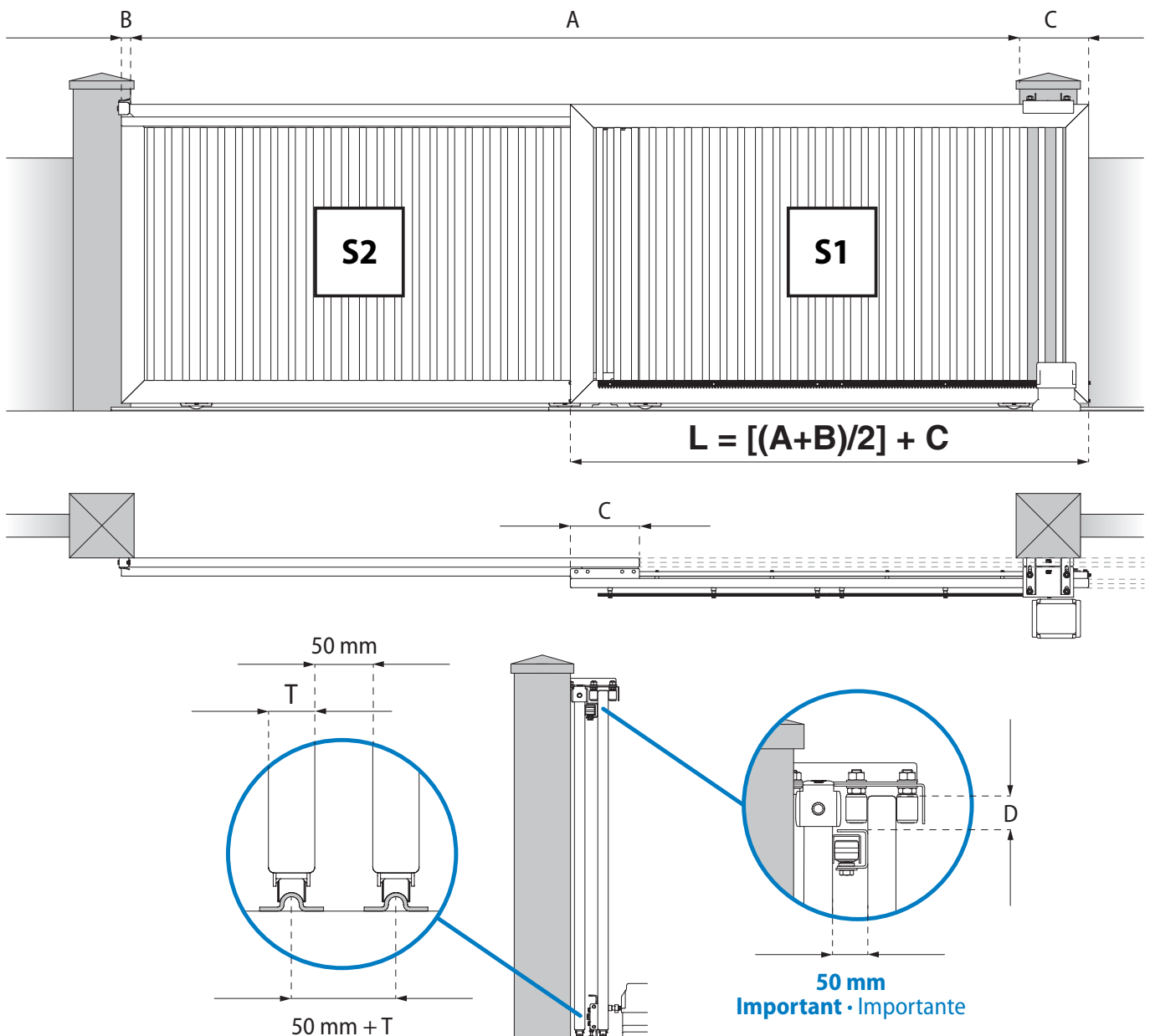
DIMENSIONAMENTO ANTE
LEAVES DIMENSIONING

CODE	APERTURA OPENING (A)	L (m) con/with B=0,1 m
KA5100.104/ KA5100.404	3	1,85
KA5100.104/ KA5100.404	4	2,35
KA5100.108/ KA5100.408	5	2,85
KA5100.108/ KA5100.408	6	3,35
KA5100.108/ KA5100.408	7	3,85
KA5100.108/ KA5100.408	8	4,35
KA5100.111/ KA5100.411	9	5,15
KA5100.111/ KA5100.411	10	5,65
KA5100.111/ KA5100.411	11	6,15
KA5100.115/ KA5100.415	12	6,65
KA5100.115/ KA5100.415	13	7,15
KA5100.115/ KA5100.415	14	7,65
KA5100.115/ KA5100.415	15	8,15

Attenzione: velocità ultima ante = velocità doppia motorizzata.
Warning: last leaf speed = motorized double speed.



INFO TECNICHE
TECHNICAL INFO

1. Massa di riferimento per la scelta del motore = $\text{Peso S1} + (2 \times \text{Peso S2})$
2. Velocità massima di S2 = 0,18m/s
3. Arresti e partenze bruschi stressano il sistema riducendone la durata inoltre possono causare malfunzionamenti e rotture
4. Considerevoli variazioni di velocità possono innescare effetti elastici tra le ante
5. É obbligatoria l'installazione delle viti di sicurezza (Fig.18) e di battenti di finecorsa
6. Tensione ottimale della fune : sufficiente a mantenere la fune orizzontale, una tensione superiore o inferiore ne abbrevia la durata.
7. Tipologia di motore consigliato: 24 Volt DC

1. Reference weight for the choice of the motor = $\text{Weight S1} + (2 \times \text{weight S2})$
2. S2 maximum speed = 0,18m/s
3. Accelerations, decelerations and high-speed variations can shorten the system duration and can cause malfunctions and disruptions.
4. Substantial variations in speed can cause elastic effects between the leaves.
5. The installation of security screws and limit stops is compulsory.
6. Cable optimum tension: enough to keep the cable in horizontal position. A lower or higher tension of the cable can shorten its duration.
7. Recommended motor: 24-volt DC

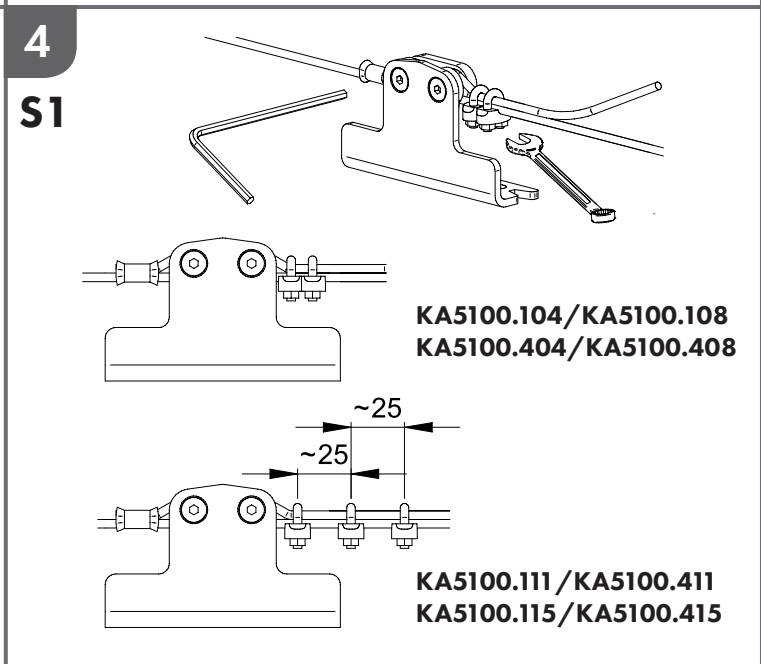
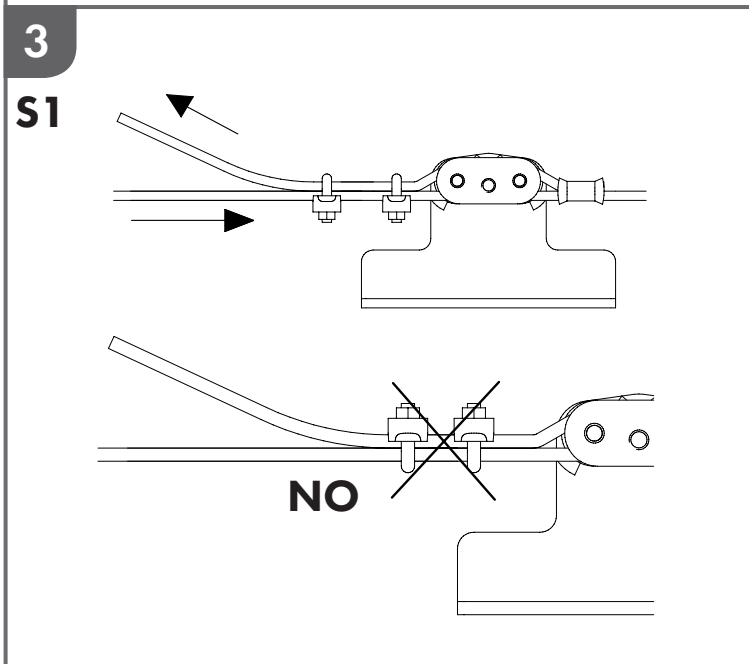
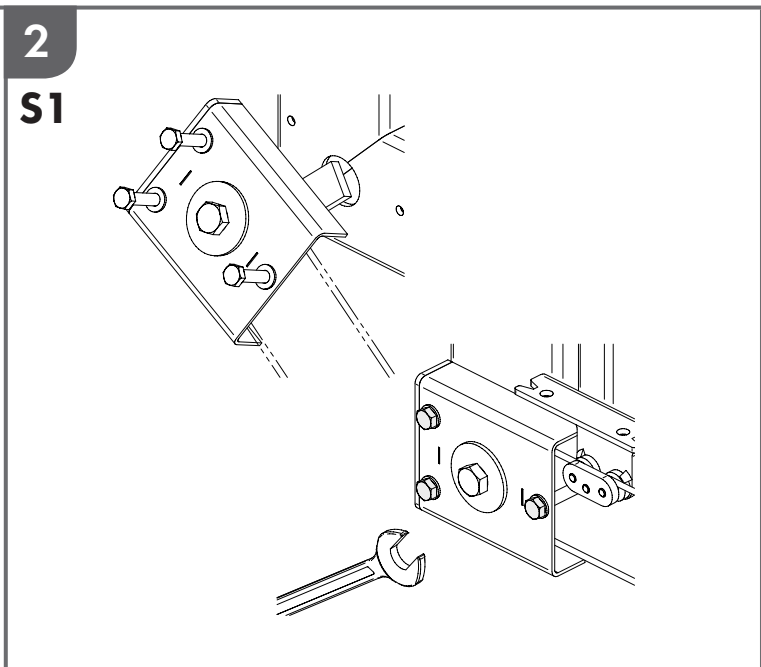
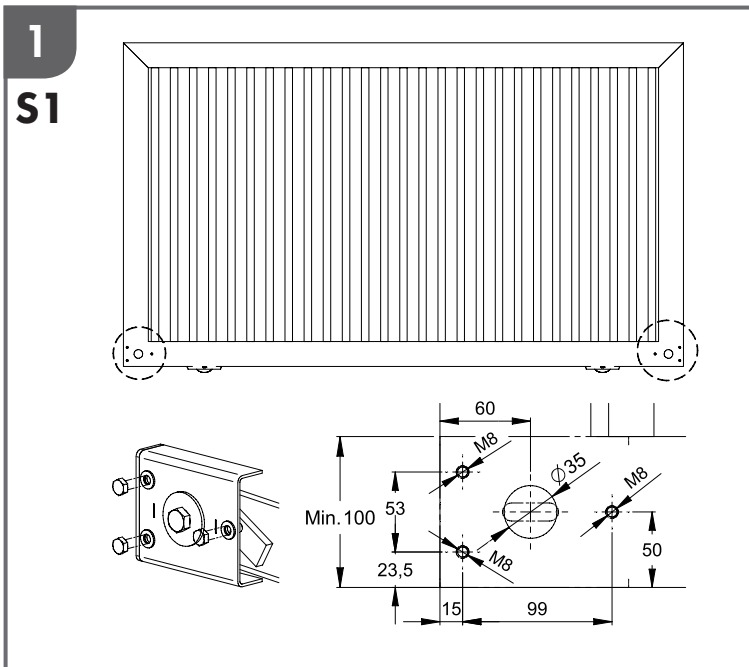



5

S1

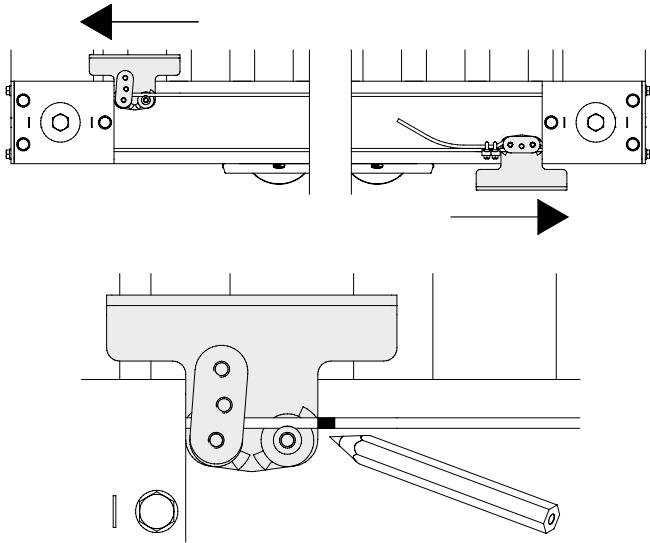

6

S1

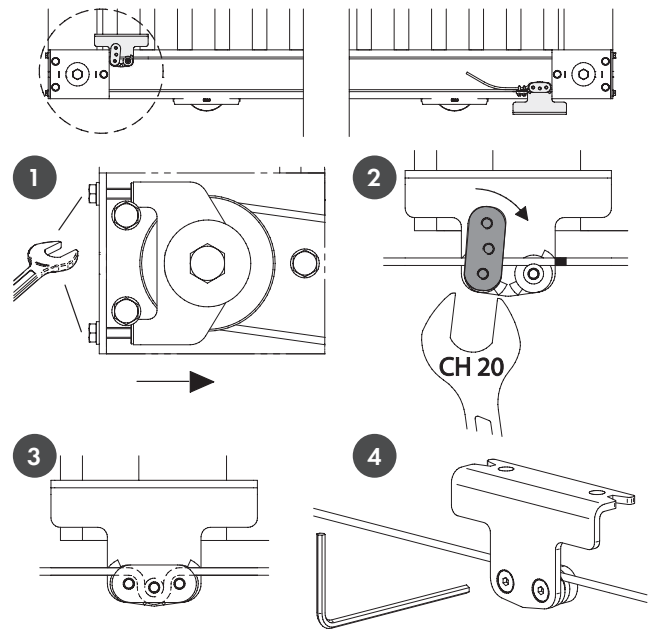

7

S1

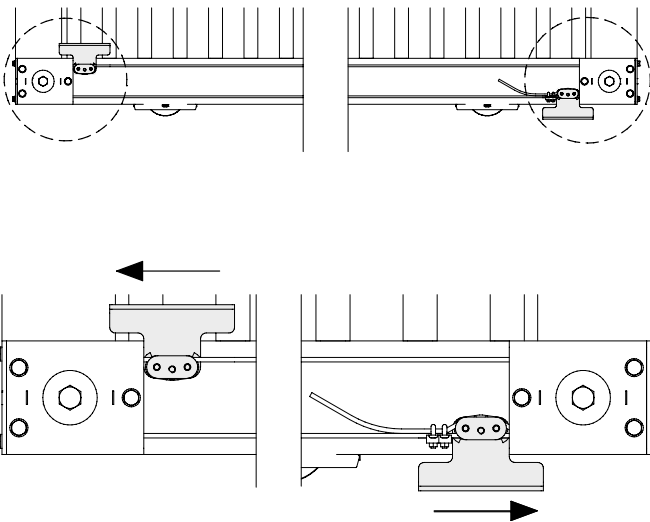

8

S1

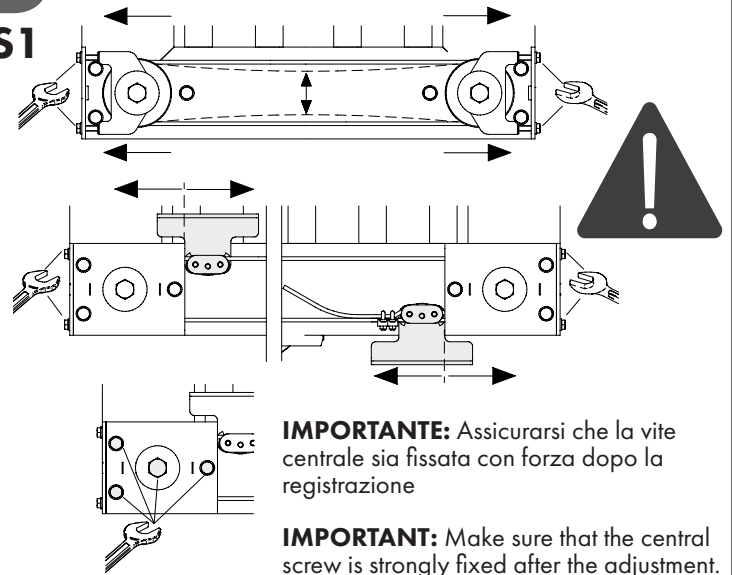

9

S1

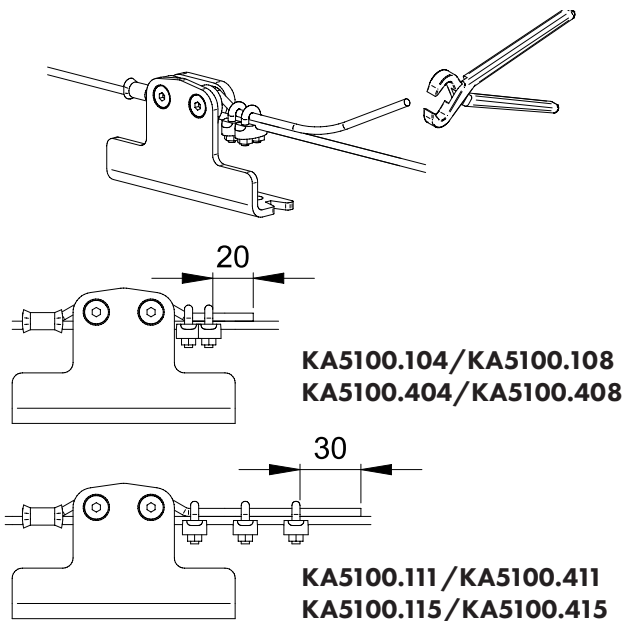

10

S1

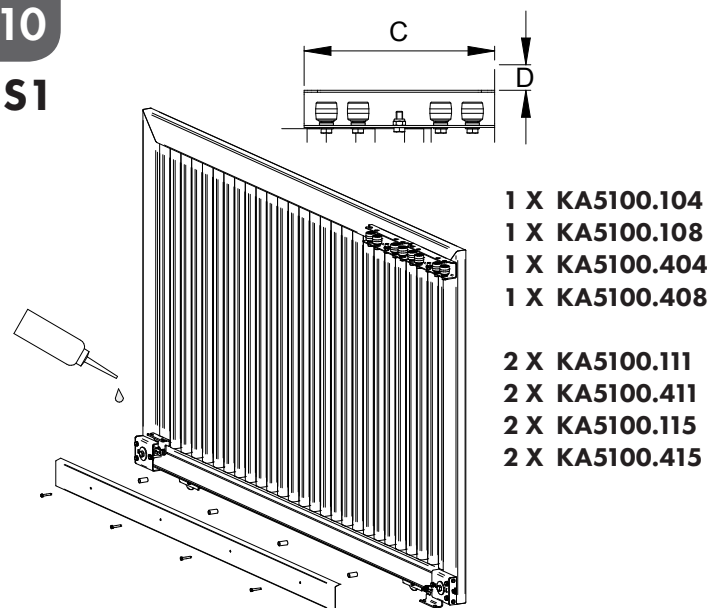



11

S2

KA5100.104/KA5100.108
KA5100.404/KA5100.408

KA5100.111/KA5100.411
KA5100.115/KA5100.415

100

S1

S2

12

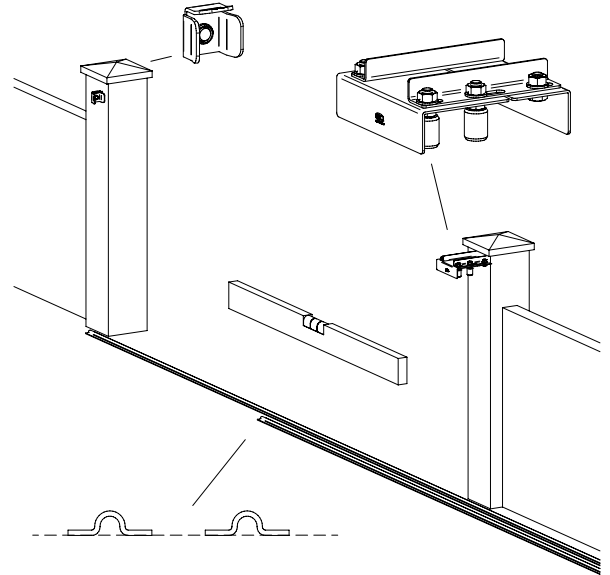

13

S1

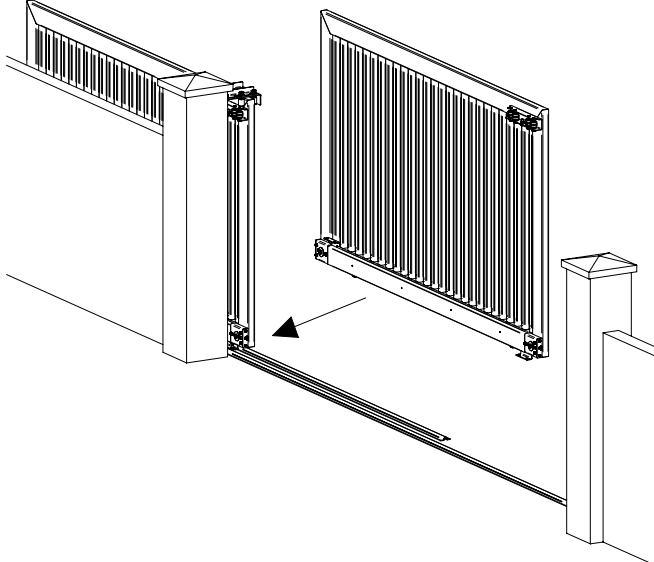

14

S1

KA5100.104/KA5100.108
KA5100.404/KA5100.408

KA5100.111/KA5100.411
KA5100.115/KA5100.415

100

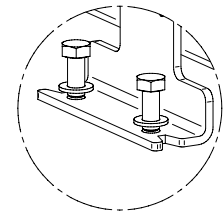

15

S1

S2

1

2

3

S2

S1

16

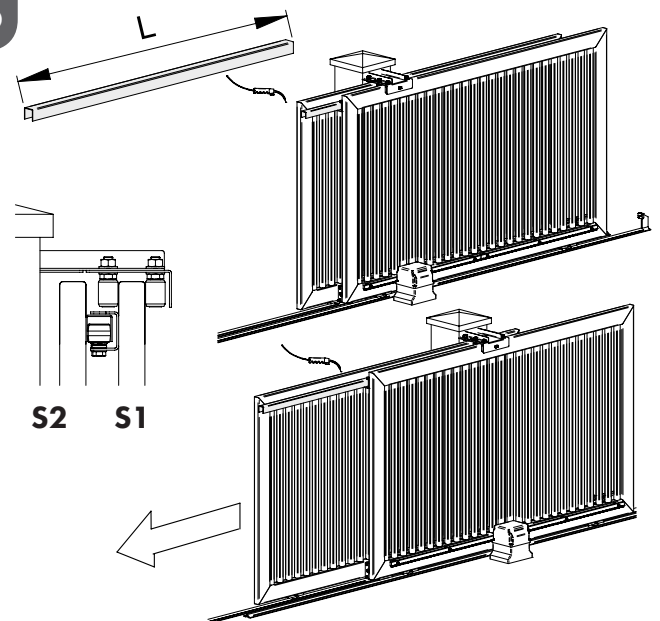

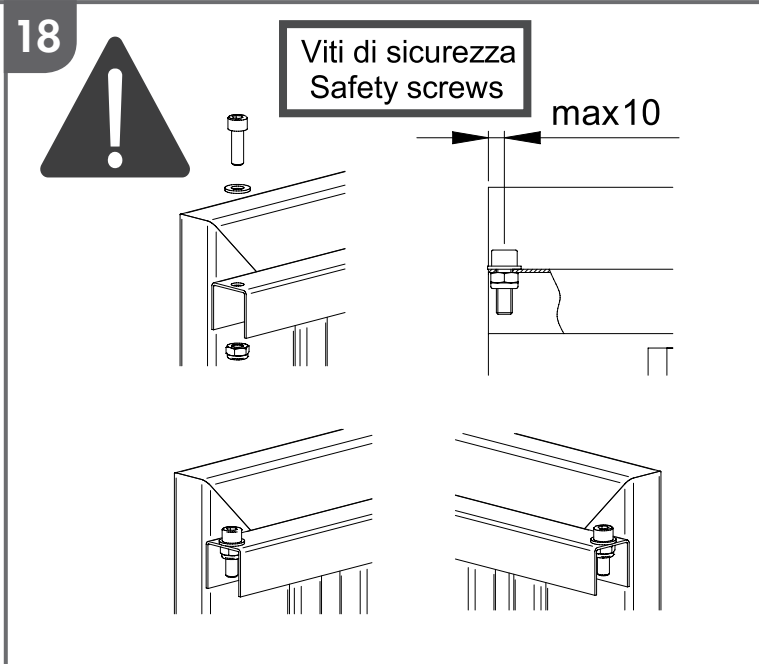
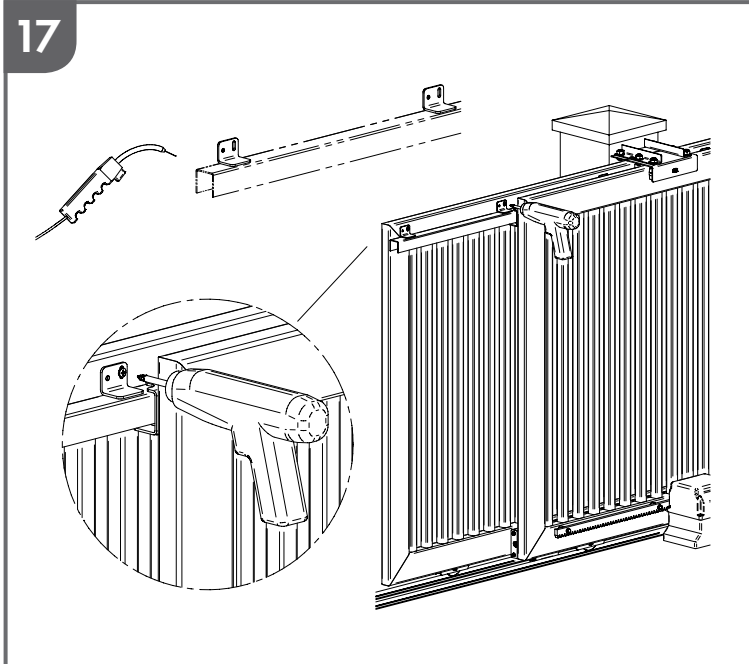

MANUTENZIONE MAINTENANCE

1. Eseguire le verifiche di funzionamento manuale a fine installazione; controllare periodicamente che il sistema sia correttamente funzionante, privo di allentamenti e ben lubrificato (consigliato ogni tre mesi e massimo ogni 8000 cicli). Se necessario intervenire regolando il tensionamento e lubrificando la fune (vedi FIG. 8-10).
2. In caso di malfunzionamenti dovuti ad usura o urti accidentali, assicurarsi che tutti i componenti atti al sostegno del cancello ed alla sua movimentazione siano integri, eventualmente procedere alla sostituzione
3. FAC garantisce il corretto funzionamento del sistema esclusivamente con l'utilizzo di ricambi originali.

Attenzione: Gli accessori compresi nei kit e l'installazione proposta fanno riferimento ad un esempio standard. Una installazione non conforme alla procedura illustrata e/o l'omissione delle corretta manutenzione potrebbero causare malfunzionamenti, compromettendo la sicurezza di persone e cose adiacenti. Verificare che gli accessori siano idonei all'opera specifica e dotarla dei necessari dispositivi di sicurezza previsti dalle normative vigenti.

Per ulteriori informazioni scrivici a : info@facsl.com

1. Perform all functioning inspections manually at the end of the installation; periodically check that the system is functioning, that it is well lubricated and does not have any loosening (we suggest a full examination every 3 months or after 8000 cycles).
2. In case of malfunctions due to wear or accidental impacts, make sure that all components apt to support the gate and its maintenance are intact. If necessary, proceed with substitution.
3. FAC ensures the system correct functioning only using original spare parts.

Attention: The kit included accessories and the proposed installation make reference to a standard example. An installation not in accordance with the illustrated procedure and the omission of the correct maintenance might compromise nearby things and people's security. Make sure that all accessories suit the specific work and make sure to use the necessary safety devices provided by current regulations.

For more information: info@facsl.com

KIT TELESCOPIQUE À DEUX VANTAUX

Kit avec accessoires en acier galvanisé et câble de tirage en acier (avec l'âme en propylène) pour la réalisation des portails télescopiques à deux vantaux.

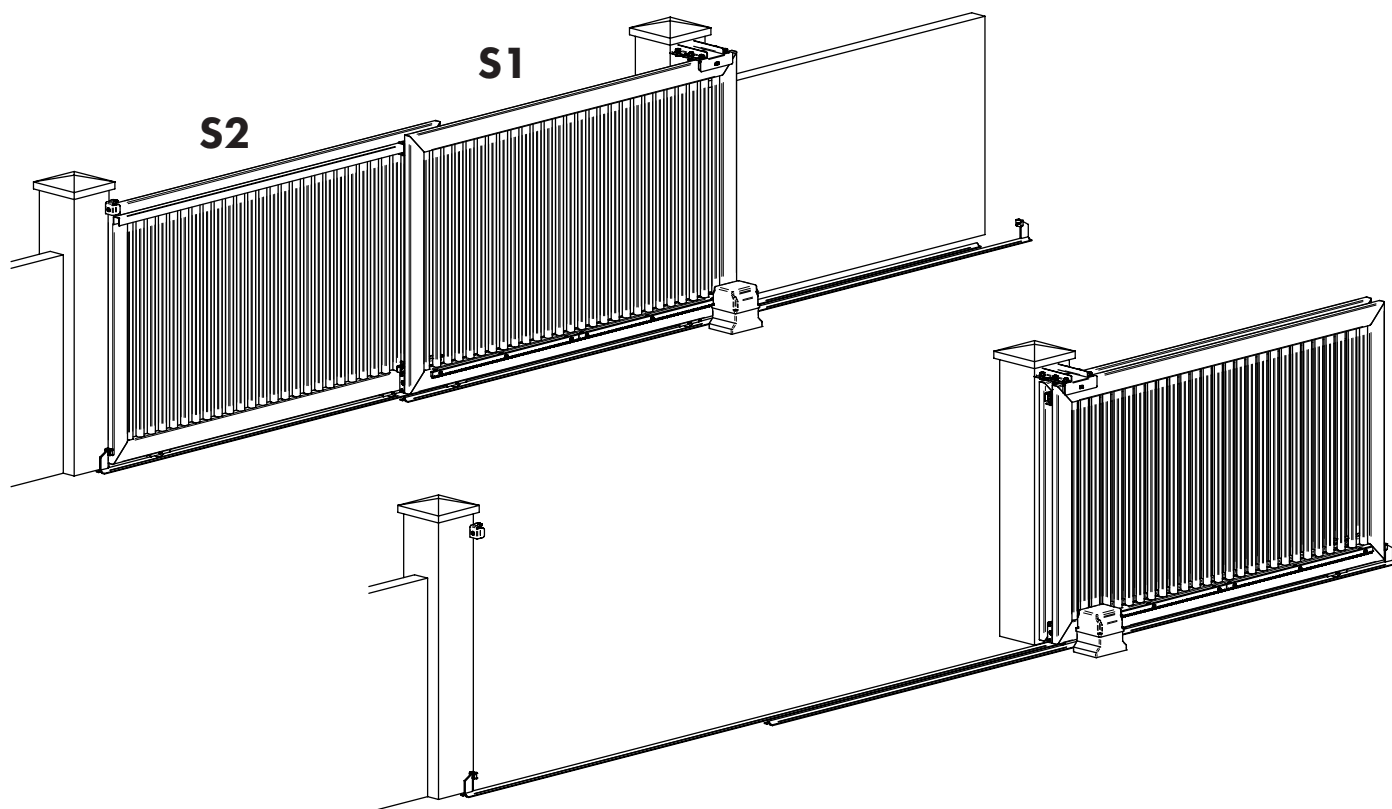

OUVERTURE JUSQU'À 4m

KA5100.104	avec rues D.90 gorge en V	M
KA5100.404	avec rues D.90 gorge ronde 20mm	M

OUVERTURE JUSQU'À 8m

KA5100.108	avec rues D.90 gorge en V	M
KA5100.408	avec rues D.90 gorge ronde 20mm	M

OUVERTURE JUSQU'À 11m









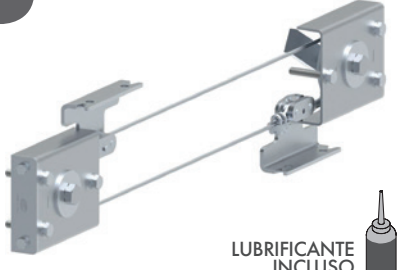

KA5100.111	avec rues D.100 gorge en V	M
KA5100.411	avec rues D.100 gorge ronde 20mm	M

OUVERTURE JUSQU'À 15m

KA5100.115	avec rues D.100 gorge en V	M
KA5100.415	avec rues D.100 gorge ronde 20mm	M





LISTE DE COMPOSANTS

<p>x1</p> 	<table border="1"> <tr> <td>A max</td> <td>4m</td> <td>8m</td> <td>11m</td> <td>15m</td> </tr> <tr> <td>n° pz</td> <td>1</td> <td>1</td> <td>2</td> <td>2</td> </tr> </table> 	A max	4m	8m	11m	15m	n° pz	1	1	2	2	<p>x1</p>  <p>LUBRIFICANTE INCLUSO OIL INCLUDED</p> 
A max	4m	8m	11m	15m								
n° pz	1	1	2	2								
<p>VA3501</p>	<p>VA3502</p>	<p>VA5101</p>										
<p>x1</p> 	<table border="1"> <tr> <td>A max</td> <td>4m</td> <td>8m</td> <td>11m</td> <td>15m</td> </tr> <tr> <td>n° pz</td> <td>2</td> <td>4</td> <td>6</td> <td>8</td> </tr> </table> 	A max	4m	8m	11m	15m	n° pz	2	4	6	8	<p>x3</p> 
A max	4m	8m	11m	15m								
n° pz	2	4	6	8								
<p>VA5201</p>	<p>VA5301</p>	<p>VA4101</p>										
<p>x4</p>  	<table border="1"> <tr> <td>A max</td> <td>4m</td> <td>8m</td> <td>11m</td> <td>15m</td> </tr> <tr> <td>n° pz</td> <td>6</td> <td>10</td> <td>13</td> <td>17</td> </tr> </table> 	A max	4m	8m	11m	15m	n° pz	6	10	13	17	
A max	4m	8m	11m	15m								
n° pz	6	10	13	17								
<p>VA1104</p>	<p>VA5411</p>											

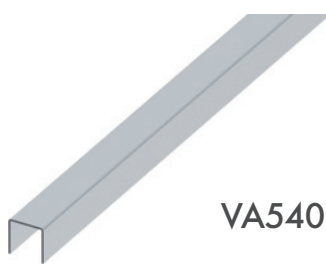

ARTICLES CONNEXES

 <p>VA5401</p>	 <p>VA2102 VA2402</p>	 <p>VA4203</p>
---	--	---



TABLEAU DES DIMENSIONS

CODE	GORGE	A max (m)	C (m)	D min (mm)	S2 max (kg)
KA5100.104	V	4	0,3	50	300
KA5100.404	U				
KA5100.108	V	8	0,3	50	300
KA5100.408	U				
KA5100.111	V	11	0,6	70	400
KA5100.411	U				
KA5100.115	V	15	0,6	70	400
KA5100.415	U				

EXEMPLE AVEC MESURES HORS TABLEAU

A = 3,5 m

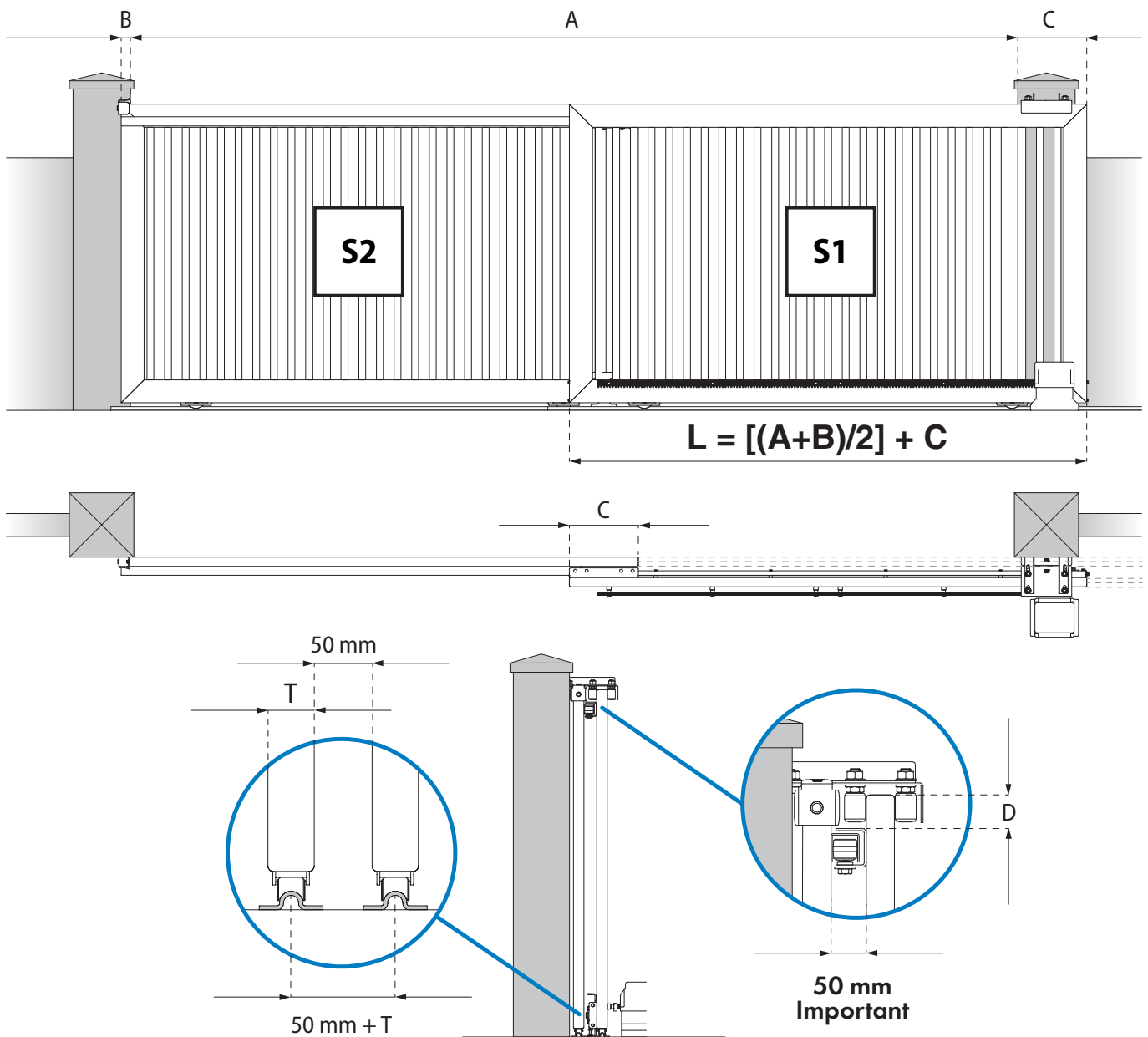
B = 0,06 m (de votre choix)

C = 0,3 m (voir tableau ci-dessus)

$L = [(A+B)/2] + C$

$L = [(3,5+0,06)/2] + 0,3$

$L = [(3,56)/2] + 0,3$

$L = 1,78 + 0,3$

$L = 2,08$

DIMENSIONNEMENT VANTAUX

CODE	OUVERTURE (A)	L (m) avec B=0,1 m
KA5100.104/ KA5100.404	3	1,85
KA5100.104/ KA5100.404	4	2,35
KA5100.108/ KA5100.408	5	2,85
KA5100.108/ KA5100.408	6	3,35
KA5100.108/ KA5100.408	7	3,85
KA5100.108/ KA5100.408	8	4,35
KA5100.111/ KA5100.411	9	5,15
KA5100.111/ KA5100.411	10	5,65
KA5100.111/ KA5100.411	11	6,15
KA5100.115/ KA5100.415	12	6,65
KA5100.115/ KA5100.415	13	7,15
KA5100.115/ KA5100.415	14	7,65
KA5100.115/ KA5100.415	15	8,15

Attention: vitesse dernier vantail = vitesse double motorisée



INFO TECHNIQUE

1. Pour le choix du moteur il faut considérer le poids sur lequel il va fonctionner : il faut donc ajouter au poids du premier vantail S1 le double du poids du deuxième vantail S2. Pour le choix du moteur = poids S1 + (2x Poids S2)
2. La vitesse maximale de fermeture du vantail est : $S2 = 0.18m/s$
3. Démarrages et arrêts stressent le système en réduisant la durée et peuvent être la cause des desserrages ou causer la rupture des certaines pièces.
4. Tension optimal du câble: suffisant pour maintenir le câble horizontal; une tension supérieure ou inférieure en réduit la durée.
5. Accélération, décélération et variations de vitesse élevées peuvent causer un effet élastique entre les vantaux pendant le mouvement.
6. L'utilisation des butées et l'installation des vis de sécurité est obligatoire.
7. Type de moteur recommandé: 24 volt DC

1

S1

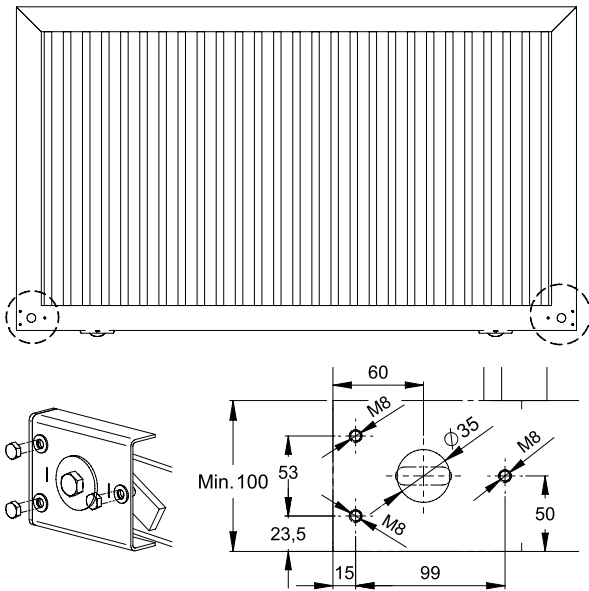

2

S1

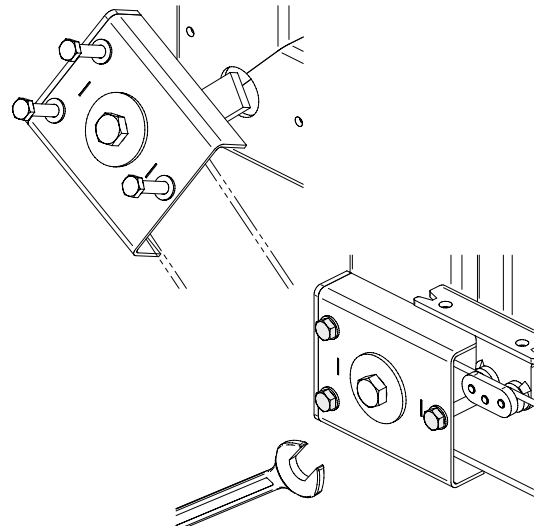

3

S1

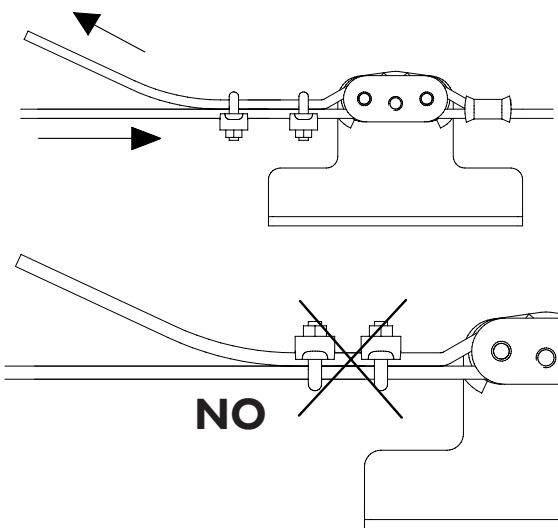

4

S1

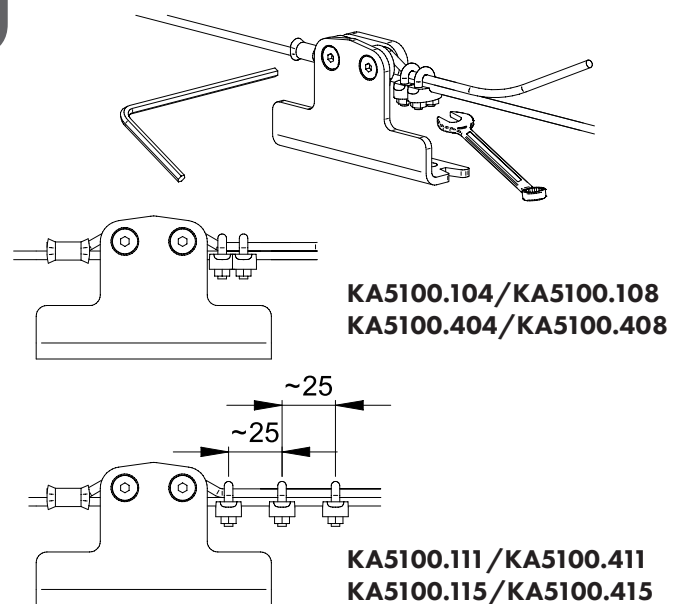



5

S1

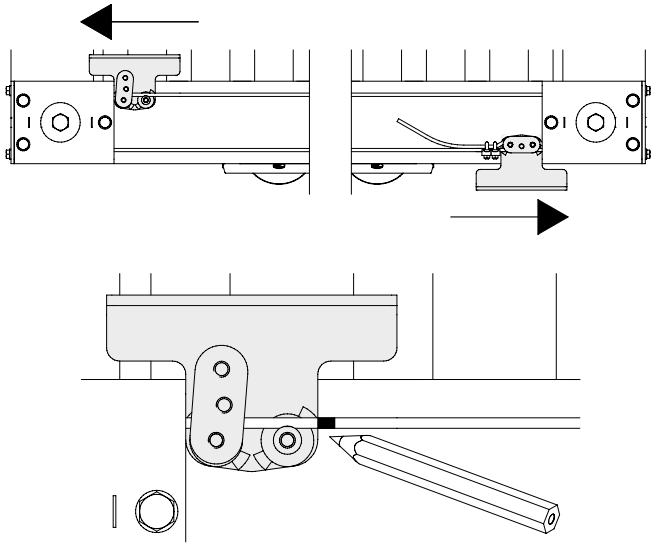

6

S1

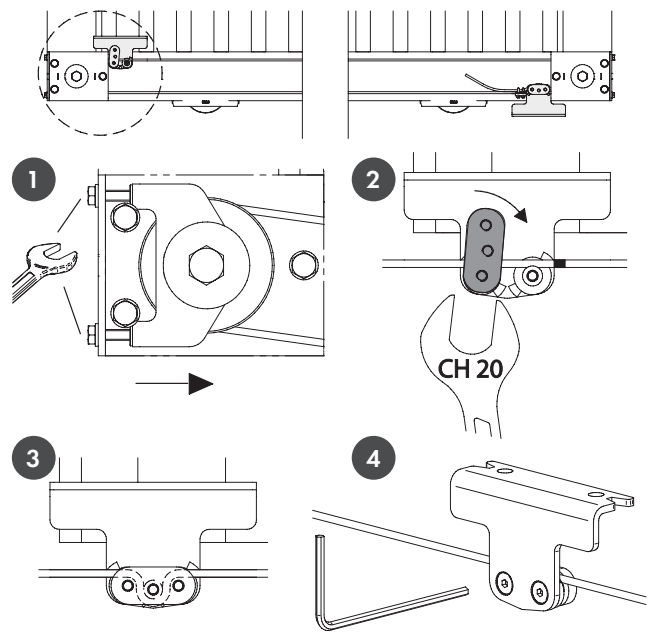

7

S1

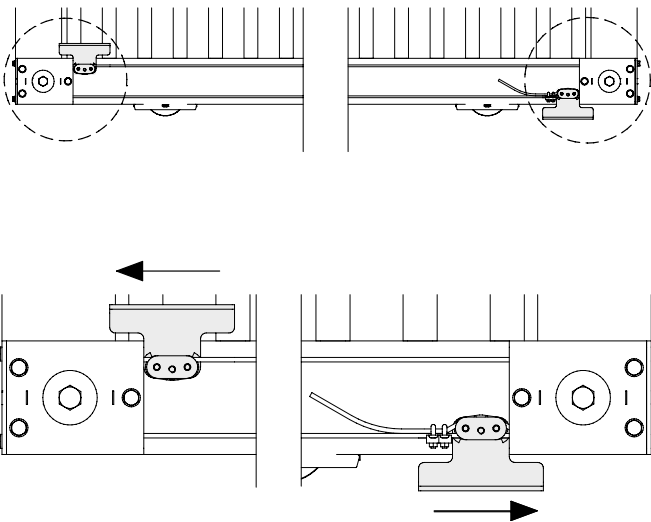

8

S1

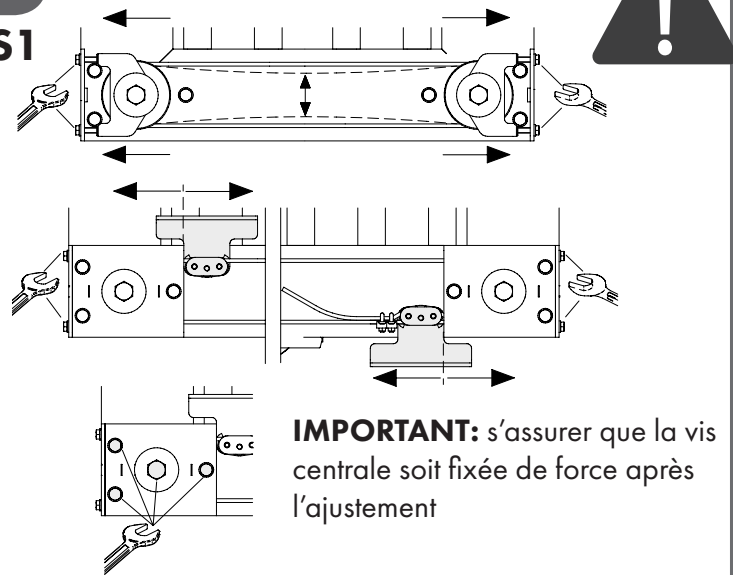

9

S1

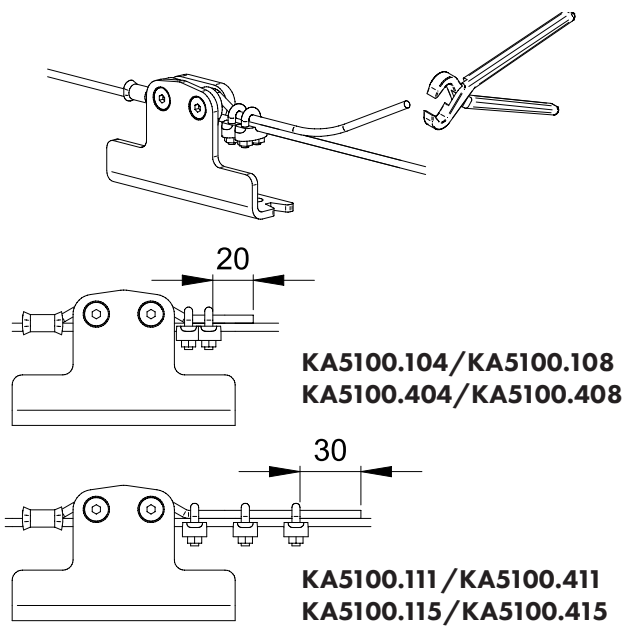

10

S1

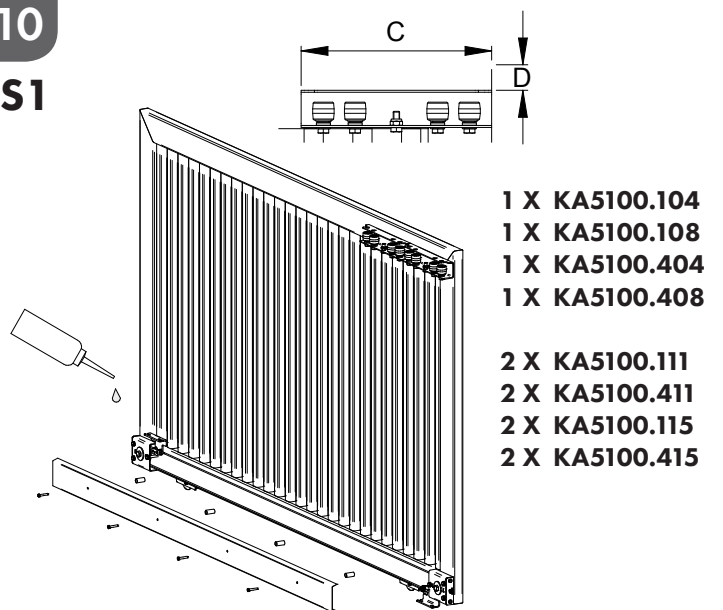



11

S2

KA5100.104/KA5100.108
KA5100.404/KA5100.408

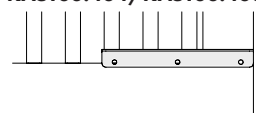

KA5100.111/KA5100.411
KA5100.115/KA5100.415

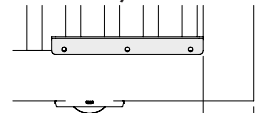

100

S1

S2

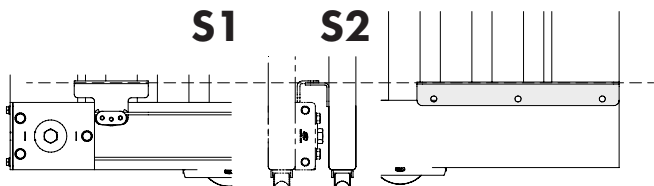

12

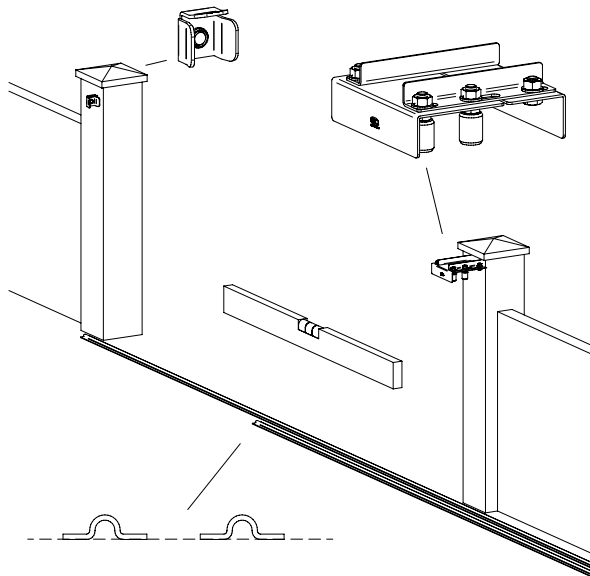

13

S1

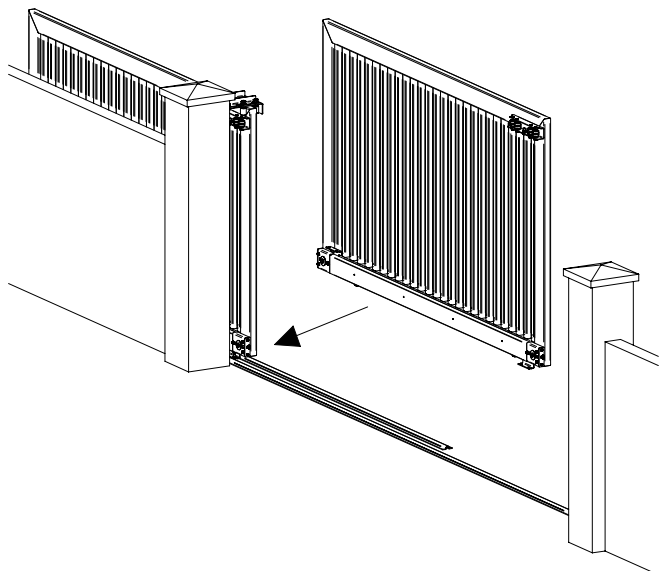

14

S1

KA5100.104/KA5100.108
KA5100.404/KA5100.408

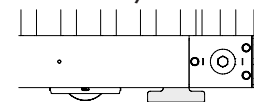

KA5100.111/KA5100.411
KA5100.115/KA5100.415

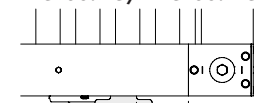

100

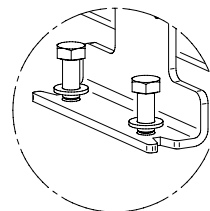

15

S1

S2

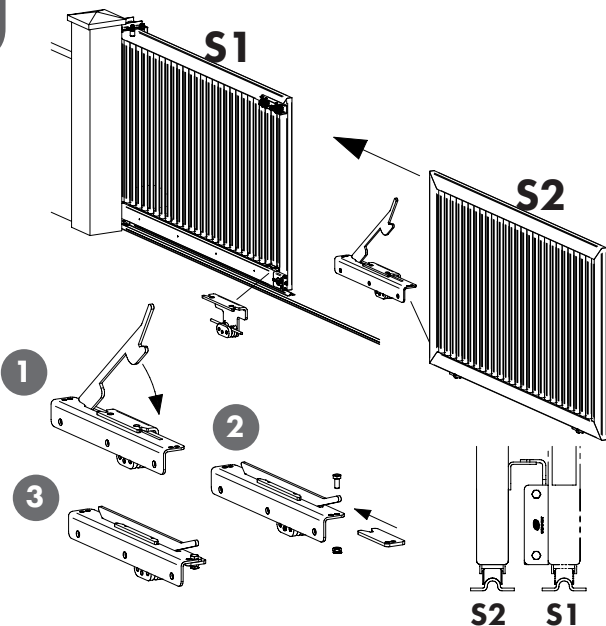

S2

S1

16

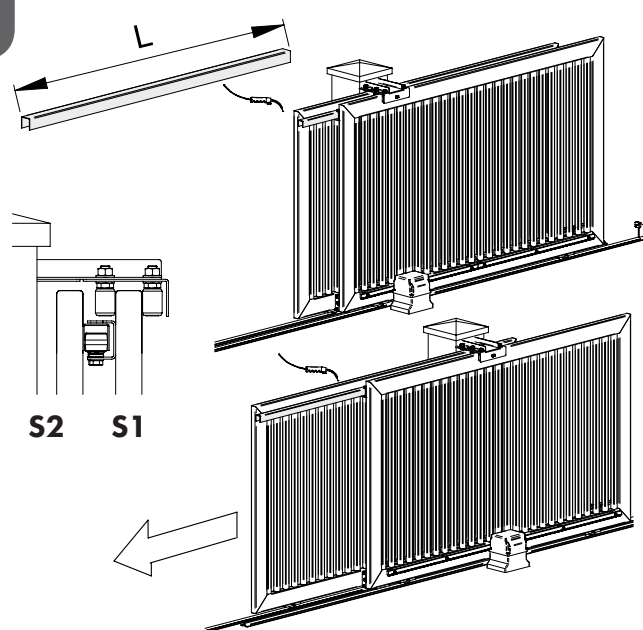

S2

S1



17

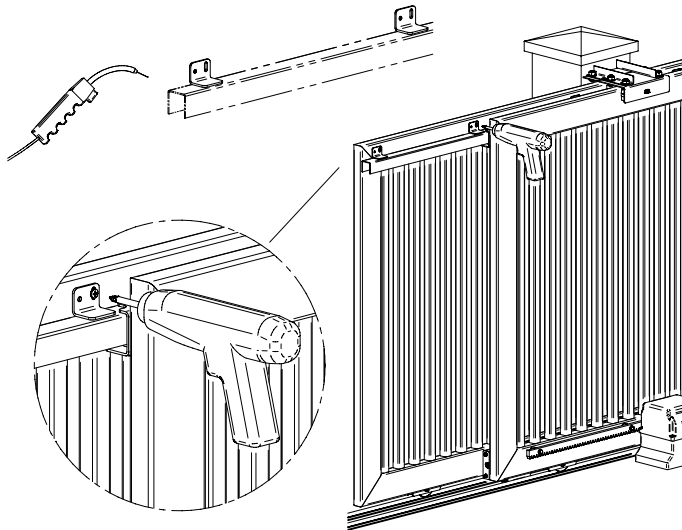

18



Vis de sécurité

max10

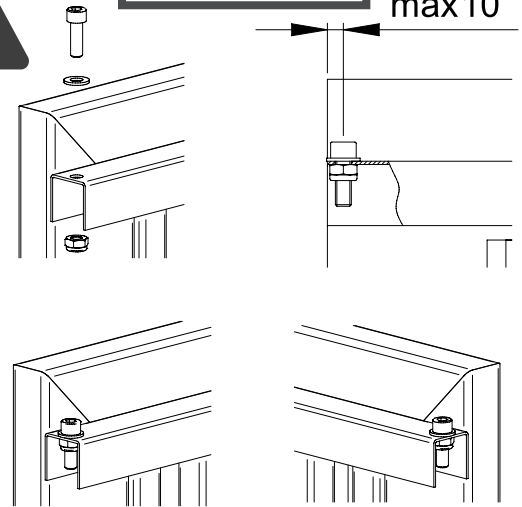

ENTRETIEN

Pour maintenir ces articles en condition de fonctionnement et sécurité optimales, il est nécessaire de suivre ces étapes :

1. Une fois le montage terminé et après avoir exécuté quelques opérations d'ouverture et de fermetures, s'assurer qu'il n'y a pas de pièces desserrées et garder toujours le système bien lubrifié. Contrôler au maximum tous les 8000 cycles et tous les 3 mois. Si nécessaire il faut intervenir en serrant les vis et en lubrifiant. (voir image 8-10)
2. En cas de chocs provoqués par de véhicules ou par d'autres causes, s'assurer que les pièces du portail n'ont pas été endommagées et éventuellement les remplacer.
3. FAC garantit le correcte fonctionnement du système uniquement si des pièces de rechange d'origine sont utilisées.

Attention: Les accessoires qui composent les kits ainsi que la proposition d'installation se réfèrent à un exemple standard. Une installation non conforme à la procédure indiquée ou la non-exécution des opérations d'entretien correctes, peuvent provoquer un dysfonctionnement du portail, en mettant en danger la sécurité des choses se trouvant à proximité. Vérifier que les accessoires soient appropriés à l'ouvrage spécifique et l'équiper de tous les dispositifs de sécurité prévus par la réglementation en vigueur.

Pour des informations supplémentaires vous pouvez écrire à info@fac srl.com